Construction and Research of a Hierarchical Model of Thermoelectric Systems Based on Multilayer Peltier Elements

✉¹ O. R. Kuzichkin, ² G. S. Vasilyev, ³ D. I. Surzhik

^{1,2,3} Belgorod State National Research University, Russia

kuzichkin@bsu.edu.ru

ssv@ores.su

³ Vladimir State Universities, Russia

info@ores.su

Received: 25th September 2020, Accepted: 07th October 2020, Published: 31st October 2020

Abstract

In order to improve the efficiency of power supply systems, it is promising to use the principle of trigeneration based on the simultaneous generation of electricity (for powering electronic devices), as well as heat and cold by thermo-electric methods (for controlling the temperature of various objects). A block diagram of an energy-saving trigeneration system based on thermo-electric modules (TEM) is proposed. A generalized hierarchical model has been developed for the study of trigeneration systems and thermoelectric systems (TES) based on multilayer Peltier elements. The model allows us to equivalently represent and analyze TES containing several control channels, local and general feedbacks, as well as nonlinear and frequency selective links, when the system is affected by external and internal disturbances. The performed simulation of TES based on the hierarchical model and piecewise linear approximation has shown the effectiveness of the approach for analyzing nonlinear modes of TES with complex structure.

Keywords

Peltier Element, Thermoelectric Module, Trigeneration System, Hierarchical Model, Dynamic Characteristic

Introduction

In modern conditions, the problem of energy saving is becoming more and more relevant, determining the competitiveness of products, environmental safety and economic well-being in general [1-5]. To improve the efficiency of power supply systems, it is promising to use the principle of trigeneration [6], which is based on simultaneous generation of electricity (for powering electronic devices), as well as heat and cold (for controlling the temperature of various objects). The thermoelectric method for obtaining heat and cold from electrical energy is based on the use of thermoelectric modules (TEM), the principle of its operation is based on the Peltier effect [7-14]. This method allows both cooling and heating of the object by simply changing the direction of current flow through the Peltier element. It is highly technologically advanced due to the absence of moving parts, which determines the convenience of using TEM in trigeneration systems in comparison with classical compressor cooling systems.

For the analysis and synthesis of energy-saving trigeneration systems, it is convenient to use the methods of automatic control theory. However, in cases where it is necessary to assess the presence of several controlled objects in the overall climate control system and in each of them a set of point sources and sensors, in this case, the task of obtaining the resulting transfer functions and their analysis will become more complicated.

To overcome this disadvantage, we can use the representation of climate control systems based on a generalized hierarchical model similar to those presented in [15-18]. The developed hierarchical model of TES should allow for a uniform representation of various system variants, in particular, taking into account nonlinear effects and characteristics (for example, nonlinear amplitude characteristics of TEM such as dependences of junction temperatures on the value of the control current). This model is built on the basis of a minimum number of similar structural blocks with the possibility of their arbitrary increase, but the integrity of the general forward and backward connections must be preserved. This model is a structural approximation of the general micro-climate control system and it contains an arbitrary number of parallel, mutually connected channels - "rows" that form a "frame" and can be unfolded in a raster mode both in "rows" (disclosure by levels) and in a "frame" with arbitrary lengths of "rows" and their number.

Block Diagram of an Energy-Saving Trigeneration System based on TEM

The design of the Peltier semiconductor element is shown in Fig. 1 (Th and Tc are temperatures of the hot and cold sides, respectively). In practice, the TEM uses multilayer Peltier elements. In TEM, several Peltier elements are

connected in series electrically and in parallel thermally. Each side of the module, depending on the current direction, contacts either p-n or n-p junctions.

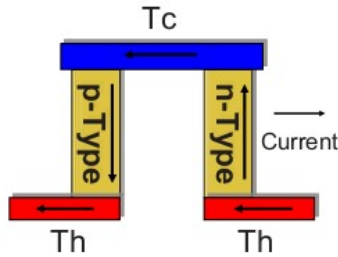

Fig. 1: Design of the Peltier Semiconductor Element

The block diagram of an energy-saving trigeneration system based on TEM is shown in Fig. 2. The main modules of this system are directly n -th objects under control ($n=1...N$) and the power supply system (PSS), which is common to them. The following notation is accepted in the diagram: SC_m is m -th solar cell ($m=1...M$), BP is a battery pack, PS is a power supply, ACSPS is an automatic control system of power supplies, CCS_n is the n -th climate control system, $TEMS_n$ is the n -th thermoelectric module of a system, VS_n is the n -th ventilation system, PST_{ni} is the ni -th point source of temperature (heat or cold), CS_{nj} is the nj -th climate sensor, $I_{CONTRnl}$ is the nl -th control signal for thermoelectric modules, T_{PSTni} is the ni -th point source of temperature (heat or cold), T_{CSnj} is temperature recorded by nj -th climate sensor.

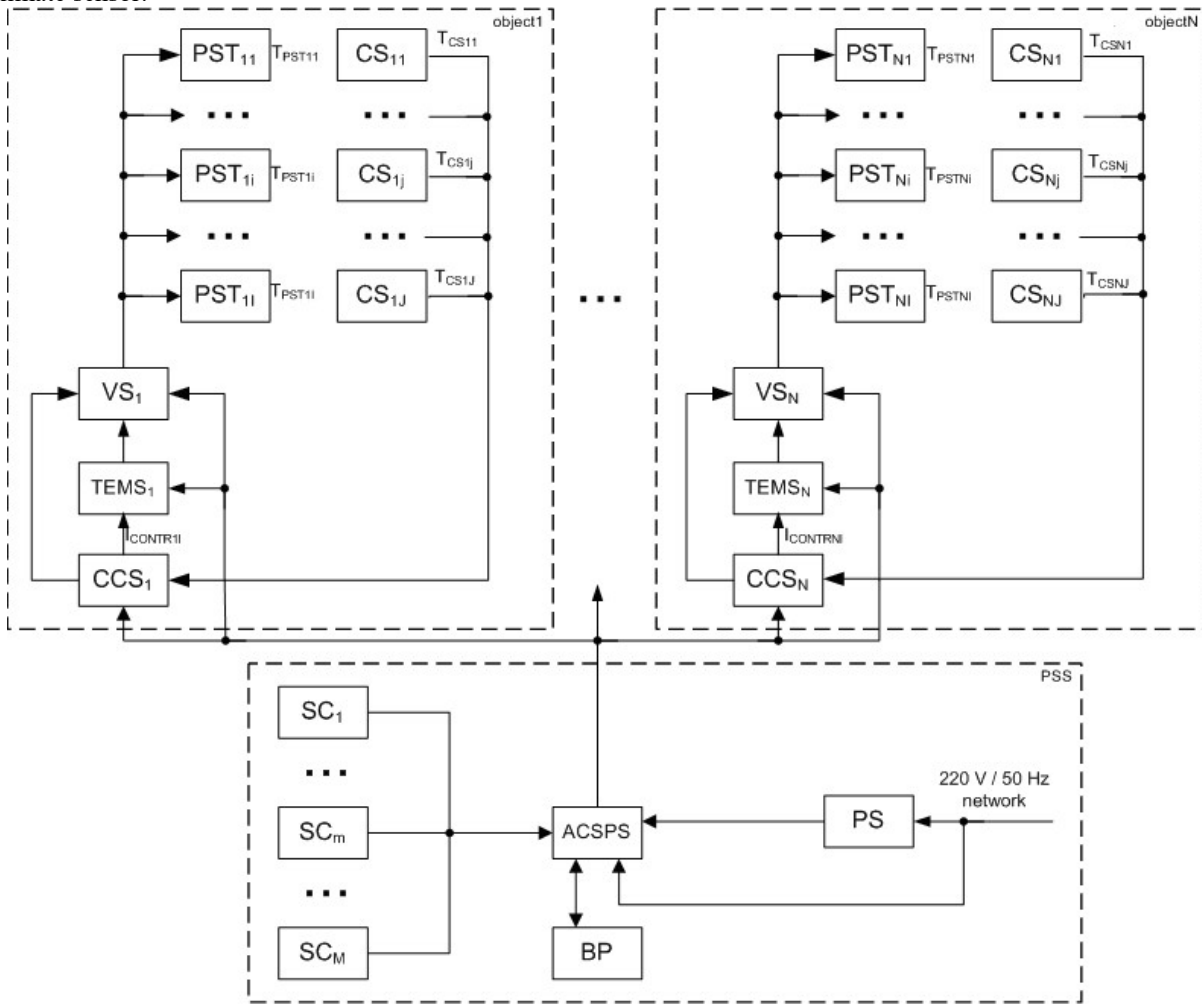

Fig. 2: Block Diagram of an Energy-Saving Trigeneration System

The main consumers of AC voltage 220 V from the power supply system are climate control systems and power units of ventilation systems, and consumers of DC voltage are TEMs based on multilayer Peltier elements. Monitoring of the temperature regime at the control objects is carried out using climate sensors that register the temperature values of T_{Snj} , which differ from the temperature values of T_{Pni} generated by point sources. The relationship between the values of these temperatures can be described in terms of the k_{nij} coefficient using a differential equation that takes into account the inertia of an arbitrary sensor with respect to the process of forming the temperature field

$$T_{Snj} + \tau_{nij} \frac{dT_{Snj}}{dt} = k_{nij} T_{Pni},$$

where τ_{nij} is the time constant (measure of inertia) of the climate sensor. This equation leads to an equivalent representation of the transfer function for an arbitrary sensor relative to an arbitrary point source of heat or cold of the n -th control object in operator form

$$H_{nij}(p) = \frac{T_{Snj}}{T_{Pni}} = \frac{k_{nij}}{1 + \tau_{nij} p}$$

which corresponds to an aperiodic dynamic link.

The resulting expression can be used as a model of the transfer function of the climate sensor. For the other parts of the functional scheme, mathematical models are presented, for example, in [19-21].

Hierarchical Model of Thermoelectric Systems based on Peltier Elements

The hierarchical model being developed should allow us to equivalently present and study various thermoelectric control systems containing multiple control channels, local and general feedback, as well as power supply systems based on the principle of trigeneration which includes simultaneous generation of electricity (for powering electronic devices), as well as heat and cooling (for controlling the temperature of various objects).

The generalized hierarchical model of signal transformer (TS) (Fig. 3) contains similar TS, control device (CU), control paths (CP) and weight distributor (WD). The transformer consists of two regulation circuits: forward and backward one.

Each CP includes series-connected detector and a filter. Blocks are designated as $TS^{x1, x2}$, where $x1$ is the level number and $x2$ is the block number. The symbols U indicate the external main input and output signals and the symbols u indicate the auxiliary signals. The upper and lower indices of signals are designated as $U^{y1, y2, y3}$, where $y1$ is the level number, $y2$ is the block number to which the signal belongs, and $y3$ is the signal identifier. The $y3$ identifier can take the following designations: 1–input signal of the block, 2–output, c –control signal of the CU, f –CP of the forward regulation circuit, b –CP of the backward regulation circuit.

The TS model can be expanded similar to a TV raster by "rows"(level disclosure) and by "frame". Fig. 2A and Fig. 2B indicate the second and the α -th ($\alpha \geq 1$) level of model disclosure, respectively. The level $\alpha=0$ corresponds to the unfolded TS.

Let's denote the matrix transfer functions of the blocks: $TS \rightarrow \Pi$, $CU \rightarrow K$, $WD \rightarrow n$, $CP \rightarrow W$. The indices of the functions correspond to the indices of their blocks. According to Fig. 1 transfer functions of the TS model have the form: for level 0 $Q^0 = \Pi^0_1$ (unfolded TS); for level 1 $Q^1 = \Pi^1_1 K^1_1 \Pi^1_2$; for level 2 $Q^2 = \Pi^2_1 K^2_1 \Pi^2_2 K^1_1 \Pi^2_3 K^2_2 \Pi^2_4$, and for level α

$$Q^\alpha = \Pi^\alpha_\beta = \Pi^\alpha_{2\beta-1} K^\alpha_\beta \Pi^\alpha_{2\beta}. \tag{1}$$

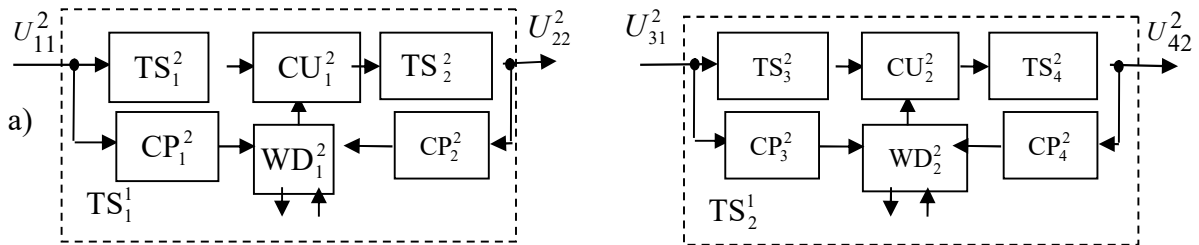

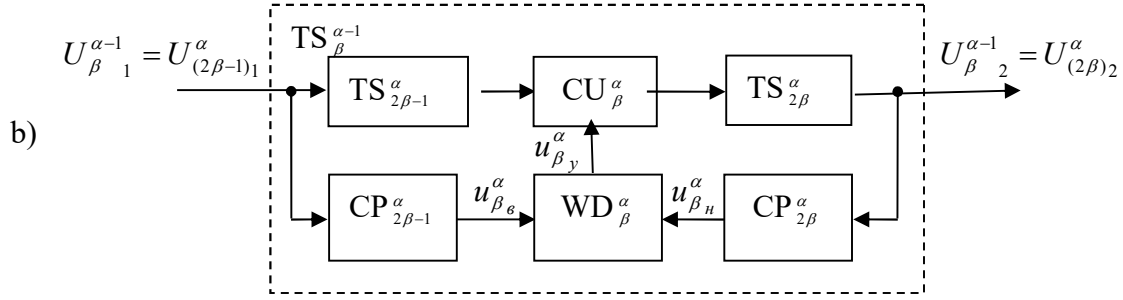

Fig. 3: Hierarchical Model of TES

Taking into account the transfer functions of the WD and CP for the current edition of the disclosed layer, we obtain

$$\Pi_{\beta}^{\alpha-1} = \frac{U_{\beta-2}^{\alpha-1}}{U_{\beta-1}^{\alpha-1}} = \Pi_{2\beta}^{\alpha} \frac{\Pi_{2\beta-1}^{\alpha} - \mathbf{f}_{\beta f}^{\alpha} \mathbf{K}_{\beta c}^{\alpha}}{\mathbf{1} + \Pi_{2\beta}^{\alpha} \mathbf{f}_{\beta b}^{\alpha} \mathbf{K}_{\beta c}^{\alpha}}, \quad (2)$$

where $\mathbf{f}_{\beta f}^{\alpha} = \mathbf{n}_{\beta f}^{\alpha} \mathbf{W}_{2\beta-1}^{\alpha}$ and $\mathbf{f}_{\beta b}^{\alpha} = \mathbf{n}_{\beta b}^{\alpha} \mathbf{W}_{2\beta}^{\alpha}$, are transfer functions of the forward and backward regulation circuits, respectively, and $\mathbf{K}_{\beta c}^{\alpha}$ is transfer function of the CU (for a signal $\mathbf{u}_{\beta c}^{\alpha}$).

Equating right parts of (1) and (2), we obtain the transfer function of CU as

$$\mathbf{K}_{\beta}^{\alpha} = \frac{\Pi_{2\beta-1}^{\alpha} - \mathbf{f}_{\beta f}^{\alpha} \mathbf{K}_{\beta c}^{\alpha}}{\mathbf{1} + \Pi_{2\beta}^{\alpha} \mathbf{f}_{\beta b}^{\alpha} \mathbf{K}_{\beta c}^{\alpha}}. \quad (3)$$

In the absence of forward and backward loops, (3) is simplified to the following equation: $\Pi^{\alpha-1} = \Pi^{\alpha} \Pi^{\alpha-1}$.

In a wide range of control currents, the Peltier element has a significantly nonlinear characteristic, and the nonlinearity of the control system blocks must also be taken into account during the modeling process. The use of piecewise linear approximation of characteristics [15-18] allows us to obtain generalized expressions of dynamic modes of TES for any order of the system under study and any character of nonlinearity. The general form of the TES's dynamic characteristic $y(t)$ is the sum of partial solutions $y_k(t)$ taking into account their time shifts \tilde{t}_k :

$$y(t) = \sum_{k=0}^{K-1} y_k(t - \tilde{t}_k) Q_{m_k} Q_{s_k} Q_{n_k}, \quad (4)$$

Where K is the number of partial solutions; Q_{m_k} , Q_{s_k} and Q_{n_k} are piecewise linear functions of approximating segments on the k -th section of the general solution. Partial solutions are determined taking into account the initial conditions (the values of the impacts and response of the system, as well as their derivatives). The characteristics of linear devices are a special case of the general expression (5) for $K=1$.

TES Modeling Based on a Hierarchical Model and Piecewise Linear Approximation

Fig. 4 shows the dynamic characteristic of TES with combined control and proportional-integrating low-pass filters of the 3rd order in the control paths, under the combined influence of external and internal disturbances. The input influence has a complex form; the destabilizing effect is harmonic; internal disturbances applied to the detectors of the control paths have the form of a Heavyside function. In this example, the hierarchical model has three non-linear links—the control device and both detectors. To calculate the dynamic characteristic, it was necessary to sum up 13 partial solutions.

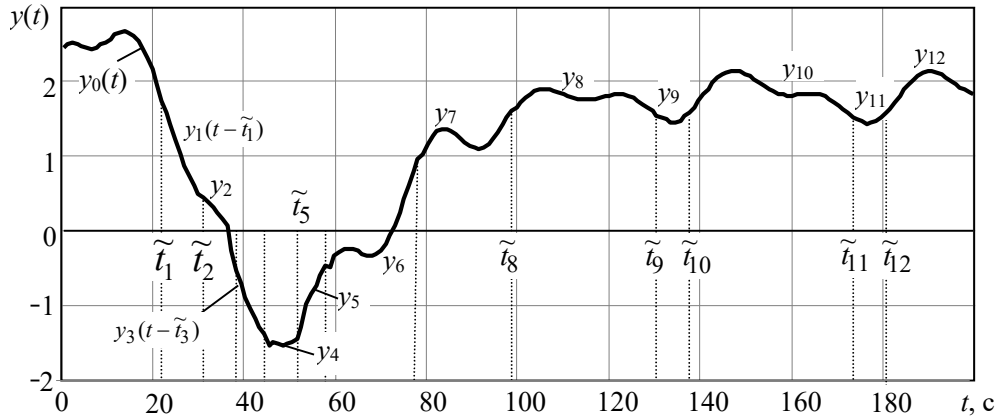

Fig. 4: Dynamic Characteristic of TES with Combined Regulation Type in Nonlinear Mode

Conclusion

The proposed method makes it possible to calculate the dynamic modes of TES with forward and backward connections, as well as various characteristics of nonlinear and frequency-selective links, for any deterministic effects, using generalized expressions of the hierarchical model. The performed simulation of TES based on the hierarchical model and piecewise linear approximation showed the effectiveness of the approach for analyzing TES with several nonlinear links under the combined influence of external and internal perturbations of complex shape. The approach makes it possible to analyze various nonlinear thermoelectric control systems containing several control channels, local and common feedback loops, as well as power supply systems based on the principle of trigeneration which includes simultaneous generation of electric energy (for powering electronic devices), as well as heat and cold (for controlling the temperature of various objects).

Acknowledgments

The article was prepared as part of the state task "Research and development of complex energy-saving and thermoelectric regenerative systems" application number 2019-1497, subject number FZWG-2020-0034.

References

- [1] N.I. Danilov, Y.M. Shchelokov "Basics of energy saving. - Ekaterinburg: HOU VPO UGTU-UPI", --564 p, 2006.
- [2] N.I. Berezovsky, S.N. Berezovsky, E.K. Kostyukevich, "Energy saving technology: Textbook. - Minsk.: BIP-C Plus, - 152p, 2007.
- [3] A.A. Andrizhievskii, V.I. Volodin, "Energy saving and energy management: Textbook". - Moscow: Higher school --294p, 2005.
- [4] M.V. Samoilov, V.V. Punicic, "Basics of energy saving: Textbook". - Moscow: BGEU. --198p, 2002.
- [5] V.L. Ganja, "Fundamentals of efficient use of energy resources: theory and practice of energy saving", Minsk.: Belarusian science, 451 p, 2007.
- [6] L.V. Galimova, R.B. Slavin "Analysis of efficiency of energy-saving system of trigeneration." Refrigerating equipment, 3, pp. 16-19, 2012.
- [7] L.I. Anatychuk, "Thermoelements and thermoelectric devices". - Kiev, 768p, 1979.
- [8] A.S. Bernstein, "Thermoelectric generators". - Moscow: Gosenergoizdat, 48 p, 1956.
- [9] O.V. Evdulov, "Development of devices and systems for cooling based on high-current thermoelectric energy converters, Dissertation for the degree of Doctor of Technical Sciences", Makhachkala, 330 p, 2019.
- [10] A.P. Zone, "Determining the conditions for obtaining the maximum energy efficiency of the Peltier element," News of Southwestern state University, 3(20), pp. 153-158, 2016.
- [11] P.I. Gnusin, "Study of the Peltier element efficiency in various operating modes," Video science, 1(1), pp. 20-27, 2016.
- [12] V.G. Ohrem, "Thermoelectric cooling using the Peltier effect," Applied physics, 5, pp. 123-126, 2011.
- [13] N.V. Gorobets, V.G. Ohrem, "Peltier thermoelectric cooler with additional conductive element," Applied physics, 4, pp. 124-127, 2007.
- [14] V.G. Ohrem, "New Peltier thermoelectric coolers for deep cooling," Applied physics, 4, pp. 121-127, 2006.

- [15] I.A. Kurilov, "Methods of analysis of radio devices based on functional approximation", Kurilov, V.V. Romashov, E.A. Zhiganov, D.N. Romanov, G.S. Vasiliev, S.M. Kharchuk, D.I. Surzhik. Radio engineering and telecommunication systems, 1, pp. 35-49, 2014.
- [16] G.S. Vasilyev, "Analysis of dynamic characteristics of signal converters based on continuous piecewise linear functions," I. A. Kurilov, G. S. Vasiliev, S. M. Kharchuk // Scientific and technical Bulletin of the Volga region, 1, pp. 100-104, 2010.
- [17] I.A. Kurilov, "Research of static characteristics of converters of signals with a nonlinear control device." I.A. Kurilov, G.S. Vasilyev, S.M. Kharchuk, D.I. Surzhik. 2011 International Siberian Conference on Control and Communications (SIBCON)/ Proceedings.–Krasnoyarsk: Siberian Federal University. Russia, Krasnoyarsk, September, 15-16, pp. 93–96. IEEE Catalog Number: CFP13794-CDR, IEEEXplore, <http://conf.sfu-kras.ru/conf/sibcon> ISBN: 978-1-4577-1069-8/11/2011 IEEE, 2011.
- [18] G.S. Vasilyev, "Analysis of dynamic characteristics of the nonlinear amplitude-phase converter at complex input influence," G.S. Vasilyev, I.A. Kurilov, S.M. Kharchuk, D.I. Surzhik, International Siberian Conference on Control and Communications, SIBCON 2013.–Catalog Number: CFP13794-CDR. SCOPUS, IEEEXplore, ISBN: 978-1-4799-1062-5/13/2013 IEEE.–p. 6693641. DOI: 10.1109/SIBCON.2013.6693641, 2013.
- [19] V.A. Grinkevich, "Synthesis of the temperature controller for the Peltier element," Collection of scientific papers of NSTU, 1(94), pp. 7-31, 2019.
- [20] V.A. Grinkevich, "Synthesis of the current regulator for the Peltier element," Collection of scientific papers of NSTU, 3-4 (93), pp. 16-39, 2018.
- [21] V.A. Grinkevich, "Research of a mathematical model of a thermostat based on the Peltier element," Collection of scientific papers of NSTU, 3(89), 62-77, 2017.